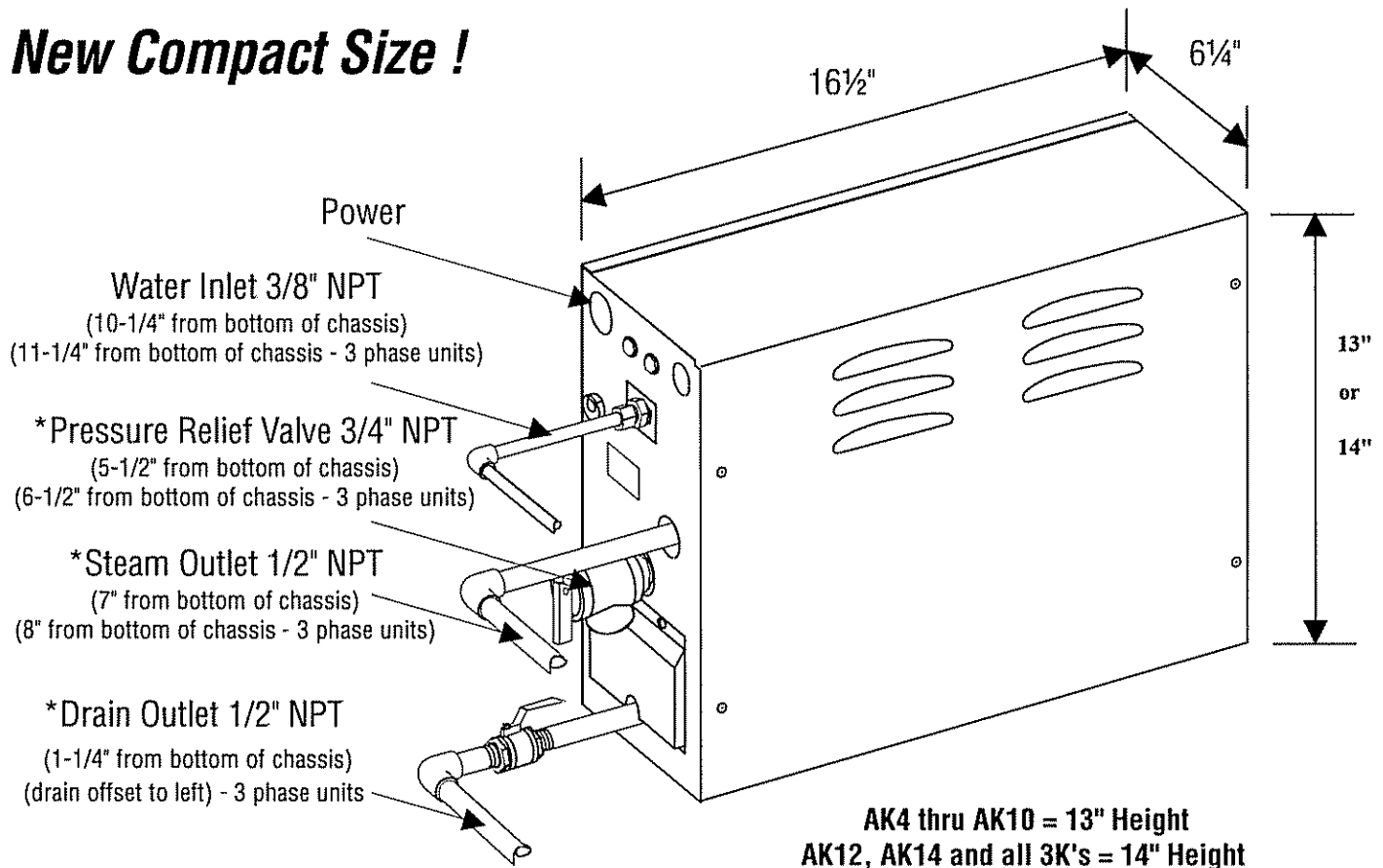

**AMEREC™****STEAMBATH GENERATOR ROUGH-IN SHEET*****New Compact Size !***

****Provide fitting to mount directly onto tank with unions for service disconnection.***

- Mount in dry, well ventilated area, not exposed to freezing temperatures.
- Mount generator level, on the wall or on its base.
- Provide adequate access for potential service needs.
- Run 3/8" copper cold water line. Install shut off valve, but do not use a saddle valve.
- Run 1/2" copper steam, not to exceed 20 ft. in length. Slope pipe to avoid condensation build up. Do not create traps. Terminate pipe in steam room 12" above finished floor, or 6" above rim of the tub if in a bathtub enclosure.
- Run 3/4" copper pressure relief line and terminate in accordance with local and national codes.
- Run 1/2" copper drain line, sloping pipe to gravity flow drain. Do not terminate into the steam room.
- Follow local plumbing and electrical codes.
- Not intended for use as installation instructions. Please refer to specific generator model installation instructions for further detail.